

Marvell ARMADA 510 Application Processor

Computing Horsepower with Seamless Connectivity for High-end Smartbook, MID and Tablet Designs



PRODUCT OVERVIEW

The Marvell® ARMADA™ 510 is a high-performance, highly integrated, low-power system-on-chip (SoC) with an ARM v6/v7-compliant superscalar processor core, hardware graphics processing unit, video decoding acceleration hardware and a broad range of peripherals. Targeted for smartbooks, thin clients, mobile internet devices (MIDs) and tablet devices, this high-performance SoC answers the need for fast processing and a rich multimedia user experience, in a low-power design that offers quick Internet browsing, software compatibility, HD video, 3D graphics and high-speed connectivity. Marvell's ARMADA 510 (88AP510) SoC gives developers a fully integrated design that provides end users with the portability and similar battery life experience of a smartphone, along with the multimedia, software and browser performance of a PC.

BLOCK DIAGRAM

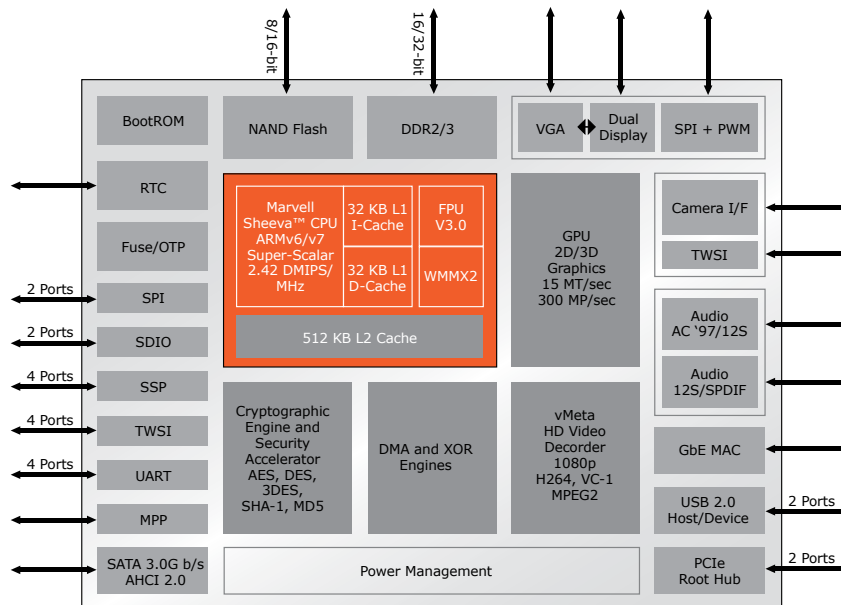

Fig 1. Marvell ARMADA 510 (88AP510) Application Processor

KEY FEATURES AND BENEFITS

FEATURES	BENEFITS
<ul style="list-style-type: none"> High-performance superscalar CPU core (1.2GHz) with 512KB level 2 cache Integrated high-speed 3D graphics and video engine 	<ul style="list-style-type: none"> Quick system response under sophisticated OS environments Fast Internet browsing response Amazing system performance for multimedia applications
<ul style="list-style-type: none"> Superior power management with long battery life design 	<ul style="list-style-type: none"> High-performance multimedia user experience <ul style="list-style-type: none"> HD video decode support up to 1080p 60Hz with excellent viewing experience 3D graphics support for gaming, UI, and Adobe® Flash® acceleration Enables cell phone-like long battery life in computing products <ul style="list-style-type: none"> Multiple power islands and cell phone class power management enables low power designs DDR3 support, one-third lower power consumption compared to DDR2
<ul style="list-style-type: none"> High speed I/O integration 	<ul style="list-style-type: none"> Complete I/O integration for simple design and high-speed functionality <ul style="list-style-type: none"> SATA AHCI 2.0 support at 3Gb/sec PCI Express i/f supports both root hub and end point modes Integrated Gb Ethernet controller USB 2.0 supports both host and device modes

▶ APPLICATIONS

The ARMADA 510 is an ideal solution for smartbook, thin client, MID, tablet computer designs as well as entertainment systems with HD video decoding requirements. The CPU, VPU and GPU (processor units) of ARMADA 510 enable an excellent multimedia experience for the user. The superscalar CPU, equipped with a large 512KB level 2 cache, provides the horsepower of a "PC class" processor enabling a rich Internet browsing experience. The integrated hardware HD video processor allows for excellent multi-media viewing, while the integrated hardware graphics processor unit (GPU) provides 2D and 3D graphics acceleration and support for the Open GL ES 2.0 and Open VG standards. With excellent application and multimedia processing capabilities, the ARMADA 510 can support a wide variety of battery-powered and wall-powered devices. Marvell offers complete development platforms for the ARMADA 510 SoC, enabling customers to start their designs without waiting for their own hardware. Development platforms are also available in multiple form factor designs for smartbook, thin client, MID and tablet computer designs from Marvell ODM and CM partners.

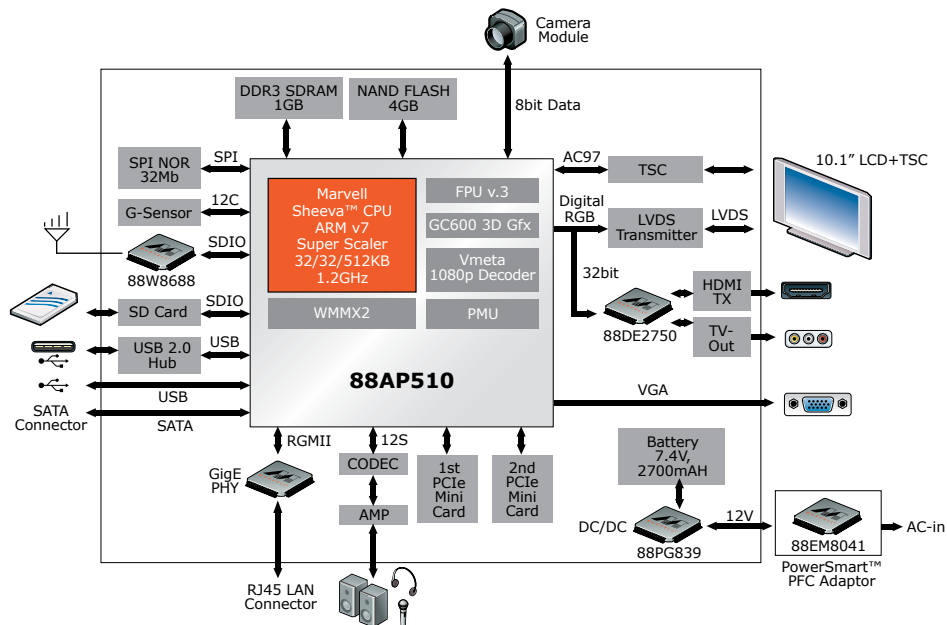

Fig 2. System Development Board Block Diagram

THE MARVELL ADVANTAGE: Marvell chipsets come with complete reference designs which include board layout designs, software, manufacturing diagnostic tools, documentation, and other items to assist customers with product evaluation and production. Marvell's worldwide field application engineers collaborate closely with end customers to develop and deliver new leading-edge products for quick time-to-market. Marvell utilizes world-leading semiconductor foundry and packaging services to reliably deliver high-volume and low-cost total solutions.

ABOUT MARVELL: Marvell is a leader in storage, communications, and consumer silicon solutions. Marvell's diverse product portfolio includes switching, transceiver, communications controller, processor, wireless, power management, and storage solutions that power the entire communications infrastructure, including enterprise, metro, home, storage, and digital entertainment solutions. For more information, visit our Web site at www.marvell.com.



Marvell Semiconductor, Inc.
5488 Marvell Lane
Santa Clara, CA 95054
Phone 408.222.2500
www.marvell.com

Copyright © 2009, Marvell International Ltd. All rights reserved. Marvell, Moving Forward Faster, the Marvell logo, Alaska, AnyVoltage, DSP Switcher, Fastwriter, Feroceon, Libertas, Link Street, PHYAdvantage, Prestera, TopDog, Virtual Cable Tester, Yukon, and ZJ are registered trademarks of Marvell or its affiliates. Armada, CarrierSpan, LinkCrypt, Marvell Smart, PowerSmart PFC, Powered by Marvell Green PFC, Qdeo, QuietVideo, Sheeva, TwinD, and VCT are trademarks of Marvell or its affiliate. All other trademarks are the property of their respective owners.
Armada510-01 10/09